

# DB-100 VARIABLE-COLOR-TEMPERATURE LED CONTROLLER

## DESIGN EXAMPLE: GUIDELINES AND SUGGESTIONS

### Introduction

The DB-100 allows a user to vary the color temperature of a lighting product from below 2500K (essentially like candlelight) all the way up to more than 6500K—that is, from “warm white” to “cool white” .The range is limited only by the choice of LEDs. Application Note AN-101 provides additional background about “Correlated Color Temperature” (known as CCT) of LED lighting sources. Sometimes CCT control is referred to as “color tuning” of white light sources.

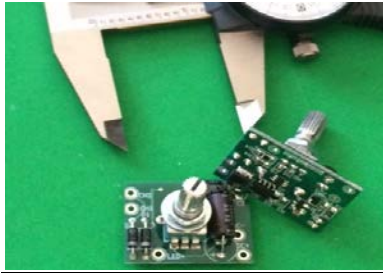

### Putting together a system

The DB -100 allows CCT control of LED arrays up to 100 watts. To implement such a system, one needs the following”

1. An LED driver (also known as LED “power supply”) powered by AC or DC. This driver determines the maximum power available for the LEDs.
2. Two separate LED strings, each having a different color temperature, and each capable of individually supplying the maximum desired watts. For example, there might be a “cool white” string of LEDs capable of 50 watts, and a “warm white” string also capable of 50 watts. But the pair of them will typically be operated at constant total 50 watts, unless dimmed.
3. Heat sink-- capable, at whatever wattage is involved, of keeping the LED mounting surface below about 75C. Much above 75C-80C LED case temperature, LED output (lumens) can drop slightly.
4. (Optional) one or more lenses or reflectors to narrow the beam and intensify it as well. For example, narrow the beam from the 120 degrees with no lens down to 20 degrees, with a lens or reflector, can intensify the beam by a factor of 10 or more

## **DIY Design Example ----Bill of Materials**

<b><u>Description</u></b>	<b><u>Manufacturer</u></b>	<b><u>Distributor part number</u></b>
<i>LED driver LPF-25D-42</i>	<i>Meanwell</i>	<i>Mouser 709-LPF25-42</i>
<i>100K DimmerPot</i>	<i>Alpha</i>	<i>Mouser p/n 313-1000F-100K</i>
<i>DB-100Controller</i>	<i>Ace Power</i>	
<i>Heat sink</i>	<i>Wakefield</i>	<i>Newark Electronics p/n 99K1617</i>
<i>Dual CCT LED COB</i>	<i>Sharp</i>	<i>Mouser 852-GW6TGCBG40C</i>
<i>2-inch acrylic hemisphere</i>	<i>Tap plastics</i>	

### **The components**

**The driver**--- The LED driver can be powered by AC or DC. In this design example we show a 120VAC-powered driver sold by Meanwell, providing a constant-current output up at 25 watts. Such power supplies can be dimmable or non dimmable. We are showing a dimmable type which can be controlled by a simple external 100K potentiometer

**The LED array**--- To make things simple, we show a standard “Chip on Board” (COB) LED made by Sharp. It is unique in that it contains two strings of LEDs chips, each of a very different color temperature. It is fairly straightforward to employ two separate COBs or two separate strings of SMD LED chips. However, the Sharp device makes it very simple by combining everything into a single component. In our case, we are conservatively employing the Sharp COB at only about 25 watts, even though it could be powered up to about 35 watts.

**The heat sink**--- LEDs of several watts or more generate substantial heat and that heat must be removed or managed in one way or the other or else LED damage will occur. If we assume we want to keep the temperatures below 75C-80 at room temperature of 25C, we want a heat sink specified about 2 degrees C per watt. Only about 80-85% of the LED wattage shows up as heat but to be safe it is a good idea to design a system as though all of the LED wattage showed up as heat for the heat sink to deal with. With this in mind we recommend a specific standard heat sink sold by prominent distributors—But any heat sink, from anybody, will do as long as it can be verified as being better than 2 degrees C per watt without any air flow. Even a flat piece of aluminum, 8” X 8” X .125” thick will do. A much smaller heat sink can be used if you have plenty of fan-driven moving air,

### Mounting the COB LED to the heat sink----

It is suggested that plus and minus wires be soldered to the COB before mounting it to a heat sink. Otherwise, it will be harder to solder because the heat sink will tend to cool off the soldering-iron heat unless a large or very hot soldering iron is used.

The COB can be mounted to the heat sink with some thermal grease or comparable “thermal interface” material. Otherwise there can be poor heat transfer from the COB to the heat sink

Putting a pair of holes in the heat sink can allow the COB to be then held down by two self-tapping screws and washers as shown in Figure 1

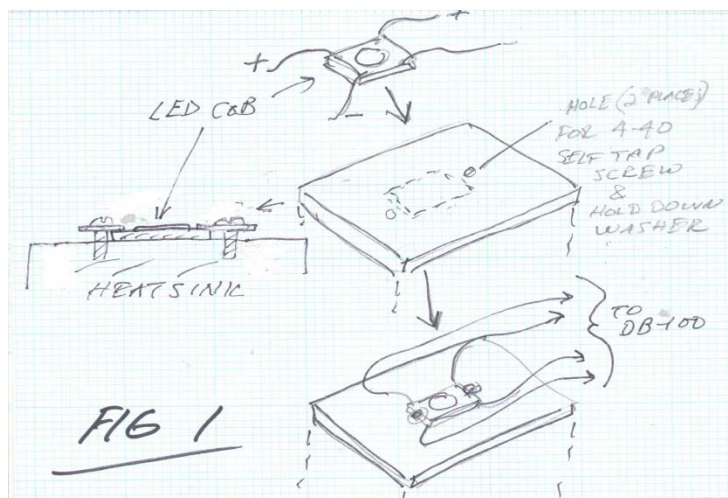

Lens or reflector--- Normally any LED or COB has a wide 120 degree beam angle. However, all makers of incandescent or LED “PAR” lamps sell such lamps as “floodlights” or “spotlights” their category determined how much they narrow down the beam (i.e. focus it)—to 60, 30 or even 10 degrees. That is done by putting an appropriate reflector or lens over the light source.

For small LEDs (surface mounted types) , 95% of applications typically use small reflectors lens or small plastic TIR lenses. But larger emitters, over ½” diameter, pose a different challenge. There are no lenses generally available for that situation and large reflectors are expensive and neither adjustable.

For DIY experimenters or other engineers looking to simply evaluate ideas, there is another good option---- an acrylic hemispherical lens, often called a “cabochon” Sold on numerous online website such as

[http://www.tapplastics.com/product/plastics/plastic\\_rods\\_tubes\\_shapes/acrylic\\_cabochons/139](http://www.tapplastics.com/product/plastics/plastic_rods_tubes_shapes/acrylic_cabochons/139)

They also have been often sold for years as “magnifiers”. With reference to **Figure 2** a 2-inch diameter hemispherical lens like this can be used to focus the LED beam of a COB the size of the Sharp unit, from 90 degrees all they down to 10 degrees just by varying the distance **D** of the lens from the surface of the LED surface. Putting another pair of holes in the heat sink can allow placement of a hemispherical lens over the COB, with beam angle set by the length of the spacer, as shown.

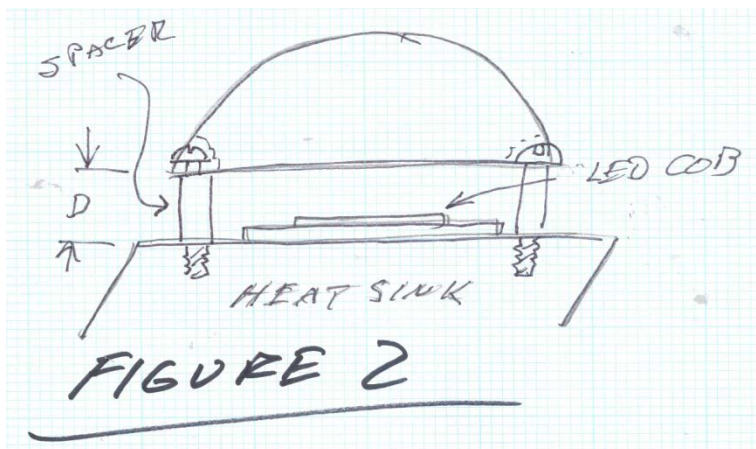

Some so-called high-powered “tactical” LED flashlights actually use this technique and use an adjustment mechanism to vary the distance and thereby create anything from wide area beam to a powerful “long-distance” very narrow beam.

### Connecting the DB-100---

**Figure 3** shows the simple connection diagram. Normally the plus and minus leads of the LED driver (power supply) would be connected directly to the plus (anode end) and minus (cathode end) of the LED string. But in this case, the LED driver is connected to the plus and minus terminals of the DB-100. If dimming is desired, a 100Kpot is connected across the two dimming terminals of the driver. The Meanwell data sheet shows a curve of driver power versus pot resistance.

**FIGURE 3**

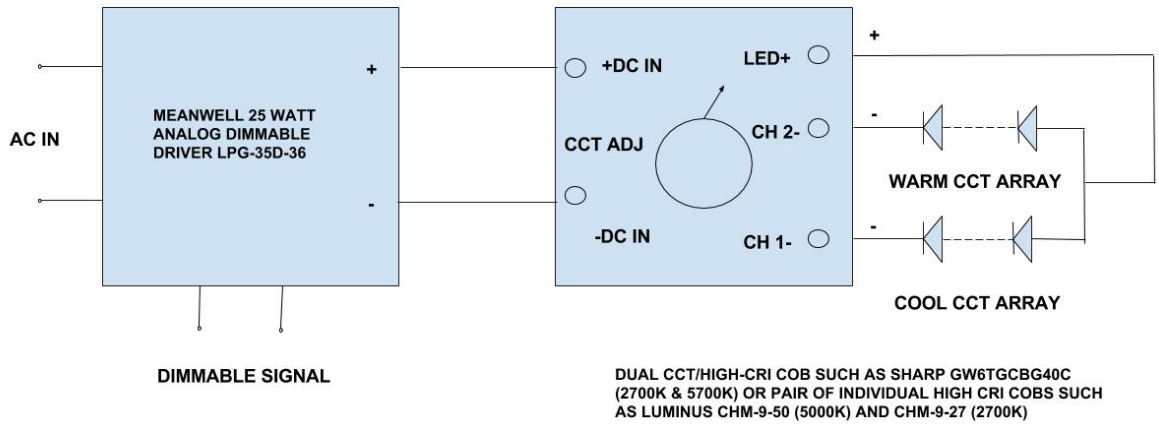

The DB-100 then “decides” how much of the available wattage from the driver it will send to the warm-white string of the COB and what percentage the cool-white LED string. The DB 100 adjustment pot determines that ratio. In the case of the Sharp dual CCT COB, one can vary the CCT from 2700K up to 5600K.

If one replaces the Sharp COB with two LED strings of 2400K and 7500K, for example, one can adjust from a “very” warm look—like candlelight or late sunset, all the way up to “very” cool white, like an overcast or rain-filled sky at 12 noon.